



FMS-350-BP

HIGH FLOW BOTTOM PORTED

NFPA/T2/6/1
BURST & FATIGUE RATING

ISO 3968
Pressure Drop vs Flow

LESS
FUEL CONSUMPTION
MORE
HORSEPOWER

FMS Filtering Systems has proven in the field to deliver Ultra-clean Ultra-dry diesel with better than ISO 11/8/7 fuel cleanliness levels, under harsh operating conditions, in a single pass, resulting in maximum engine power with a perfect performance.

FMS ultra-filtration means optimal handling and control of particulate and water contamination of diesel fuel, which is a must in modern engines that handle very tight tolerances and very high injection pressures.

It is well known that contamination will reduce the life time of your components and lubricants, but the proper understanding of the relation between ISO certified fuel cleanliness and the life time of the components should always be the focus of a good predictive maintenance practice.

As expert consultants, we at FMS evaluate your current condition and design a contamination control strategy, according to your specific needs, to keep your operation within the optimum ISO 4406 standard.

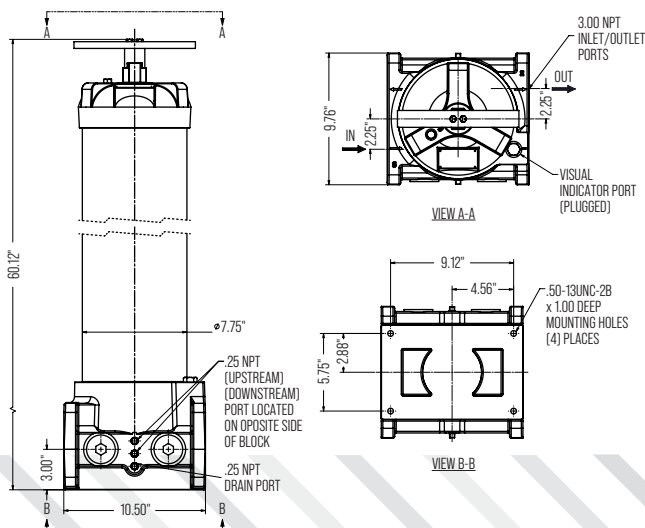

FMS FILTRATION BENEFITS

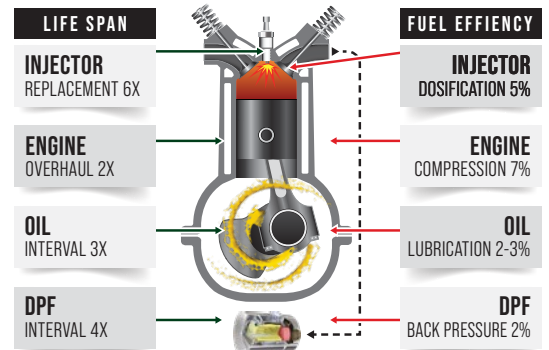

HOUSING TECHNICAL SPECIFICATIONS

Max. Flow per Housing	350 gpm
Porting	3" NPT
Additional Ports	2 x test points, 2 x manometers, 1 x Delta P indicator (pop-up or sensor)
Elements Options	FMS-1/350-P
Max. Operating Pressure	500 psi (35 bar)
Min. Yield Pressure	2500 psi (172 bar)
Temperature Range	-20°F to 225° (-29°C to 107°C)
Bypass Setting	30 psi (40 psi optimal)
Porting Base	Cast Aluminum
Element Case	Steel
Cap	Ductile Iron
Weight	210 lbs
Element Change Clearance	36.8" (859 mm)



FMS-1/350-P

BULK FUEL FILTER

100% SYNTHETIC MEDIA

ULTRA CLEAN DELIVERY

Our high flow systems are ideal for intake rates up to 350 gpm. At this point, 95% of all contamination, filter maintenance and potential flow drops are controlled. An ISO audit upon reception of the fuel allows us to know what the supplier delivers.

FMS is the first ISO supplier to guarantee ISO 11/8/7 diesel compliance at the lowest cost per gallon. Improving diesel quality optimizes engine power and reduces fuel consumption, which means great savings for the engine owner.

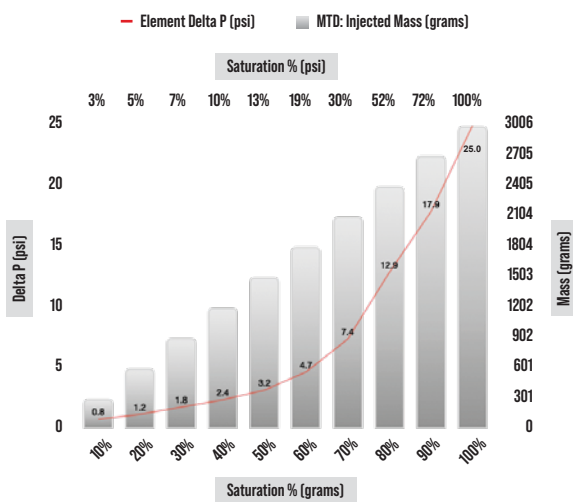

FMS Filtering Systems has proven in the field to deliver Ultra-clean Ultra-dry diesel with better than ISO 11/8/7 fuel cleanliness levels, under harsh operating conditions, in a single pass, resulting in maximum engine power with a perfect performance.

THETA 4>4310 SINGLE PASS TEST

	ISO CODES	PARTICLES		
		4 µm	6 µm	14 µm
Reservoir Contaminant Level	22/21/18	31898	14071	542
Average Cleanliness at Downstream	10/8/6	7.4	1.7	0.34

ELEMENT TECHNICAL SPECIFICATIONS

Efficiency	Beta 4-4193 (ISO 16889:99)
DHC	3000 grams (MTD)
Maximum Pressure	150 psi
Recommended Flow	350 gpm
Dimensions	42x6.25x6.25"
Weight	21 lbs
Housings	FMS-350-BP

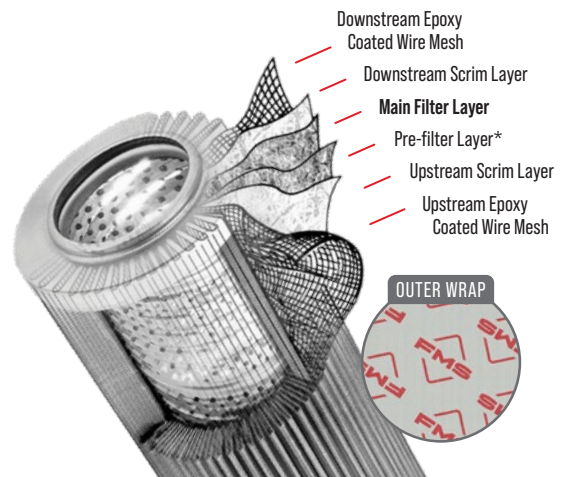

MULTILAYER FILTER MEDIA

Intricate passageways for the maximum entrapment of dirt particles

MULTILAYER MEDIA SUPPORT

Provides strength and protection to the support media layers

HIGH COST-EFFECTIVE MEDIA AREA

Less restriction, lower pressure drop, lower hydraulic load

WIRE MESH UPSTREAM AND DOWNSTREAM

Better pleat stability



SCAN TO VISIT OUR WEBSITE



FMS INTERNATIONAL INC.

580 W Park Rd Leetsdale, PA 15056 USA

+1 724 340 4210
info@fms-filtration.com
fms-filtration.com