



**INCREASED
SERVICE LIFE
MAXIMUM
EFFICIENCY**

The FMS bypass ultra-filtration system is a secondary filtration unit that aims at super-cleaning the engine oil through very high efficiency. It has a high contaminant holding capacity, and retains even the smallest particles.

Bypass filtration should be used as standard equipment on heavy-duty and large turbodiesel engines, and is recommended as an optional application on all other equipment from major engine manufacturers.

IMPORTANT INFORMATION YOU SHOULD KNOW:

- Bentley Tribology Services defines the maximum contamination limit in an engine oil to be 17/16/13 (ISO code 4406).
- Multiple tests have proven that a cleaner engine oil decreases fuel consumption by 2%-3%.
- More than 80% of the contamination removed by the bypass filter is of organic origin: sludge, varnish, resin, soot, unburned fuel, among others.

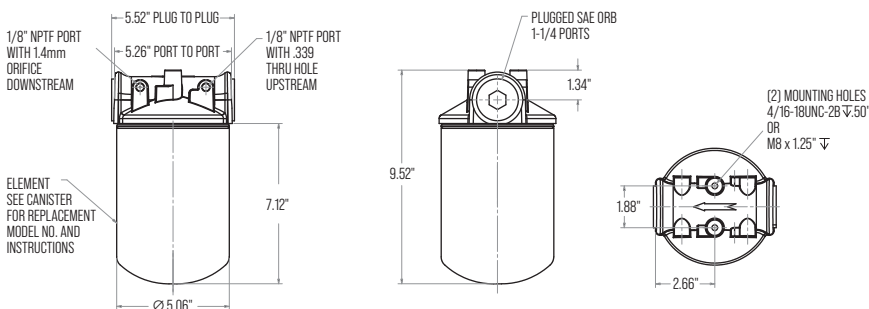

REDUCES component wear by 10% to 65%

PROTECTS the original OEM filter

REDUCES fuel consumption by 2-3%

REDUCES lube oil maintenance intervals

REDUCES engine wear, increasing engine life

INCREASES oil volume

— BENEFITS OF LUBE OIL BYPASS FILTRATION —

HOUSING TECHNICAL SPECIFICATIONS

Max. Flow per Housing	0,4 gpm
Porting	1/8" NPT
Additional Ports	2 x 1/8" NPT (US & DS)
Elements Options	FMS-3/0.4-P up to 60 gal sump FMS-3/25-P up to 100 gal sump
Max. Operating Pressure	100 psi (7 bar)
Min. Yield Pressure	150 psi (10 bar)
Temperature Range	-20°F to 225° (-29°C to 107°C)
Porting Base	Cast Aluminum
Element Case	Steel
Weight	5 lbs (2.3 kg) FMS-3/0.4-P 6 lbs (2.7 kg) FMS-3/25-P
Element Change Clearance	2.5" (65 mm)





ULTRA CLEAN DELIVERY

Particles contaminated lubricant is one of the main causes of equipment stop and failures, damaging individual components that keep equipment running. Therefore, removing particle contamination of your lubricating fluids must be your top priority.

FMS oil bypass filtration system guarantees sump oil is constantly being cleaned any time the engine is running, and it will be filtered down to OEMs recommended optimum fluid cleanliness target size ISO 16/14/12 or better, resulting in engine's oil performance that exceeds your expectations.



ELEMENT TECHNICAL SPECIFICATIONS

Efficiency	Beta 4-4193 (ISO 16889:99)
DHC	200gr @0.4gpm (MTD) FMS-3/0.4-P
	155 grams (MTD) FMS-3/25-P
Maximum Flow	0.4 gpm
Max. Operating Pressure	100 psi (7 bar)
Min. Yield Pressure	150 psi (10 bar)
Dimensions	7.12 x 5.52 x 9.52" FMS-3/0.4-P
	10.80 x 5.52 x 9.52" FMS-3/25-P
Weight	5 lbs (2.3 kg)
Housings	FMS-0.4-SP

PERCENT WEAR WITH FULL FLOW AS BASELINE

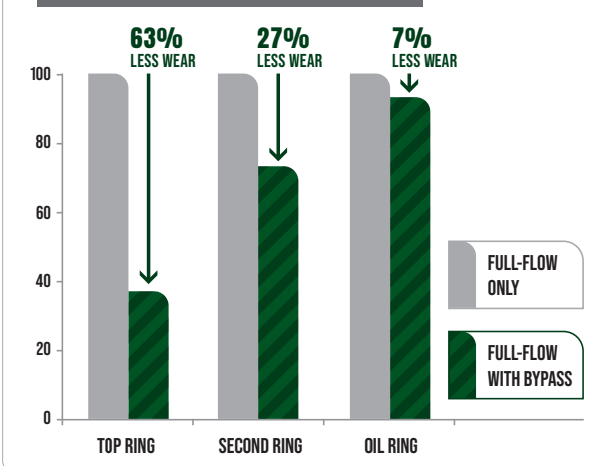

BYPASS FILTRATION REDUCES ENGINE WEAR

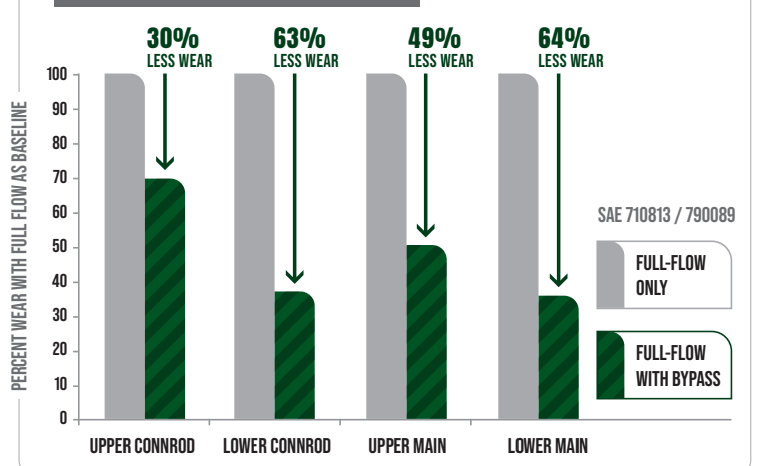

* Diesel ISO 11/8/7 has demonstrated a decrease of up to 47% in cylinder wear.
* The tables shown apply to an engine that consumes ISO 11/8/7 diesel.



SCAN TO VISIT OUR WEBSITE



FMS INTERNATIONAL INC.

580 W Park Rd Leetsdale,
PA 15056
USA

+1 724 340 4210
info@fms-filtration.com
fms-filtration.com