



FILTER INSTALLATION

FMS-0.4-SP



- Determine an engine pressure point, never use the turbo lubrication line.
 - Determine a return point with NO pressure in the engine crankcase.
 - Use hoses with a steel core, strapped that support a minimum of 150 psi and 120 C.
 - Attach the filter using the holes/thread in the filter head.
 - Connect the pressure hose to one of the 1.8" NPT ports in relation to the flow arrow.
 - Connect the return hose to the crankcase (without pressure) in one of the 1/8" NPT ports following the flow arrow.
- Note that the return ports have a 1.5mm hole that acts as a flow/pressure regulator to protect engine pressure.
- Place the manometers choosing a pressure port and a return port.
 - The pressure gauge will measure engine pressure and the differential with the return gauge will define the saturation of the element to be changed at 20 psi delta P.

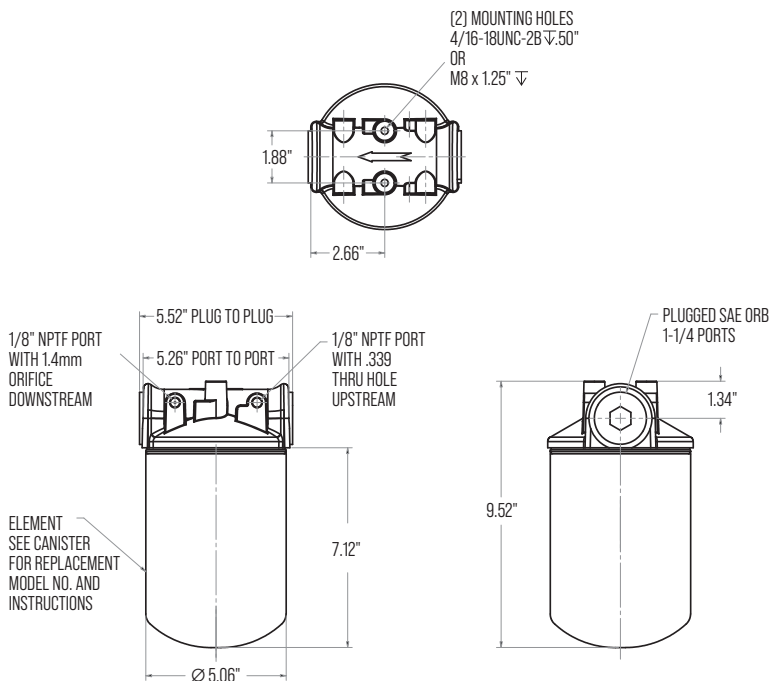

HOUSING TECHNICAL SPECIFICATIONS	
Max. Flow per Housing	0,4 gpm
Porting	1/8" NPT
Additional Ports	2 x 1/8" NPT (US & DS)
Elements Options	FMS-3/0.4-P up to 60 gal sump FMS-3/25-P up to 100 gal sump
Max. Operating Pressure	100 psi (7 bar)
Min. Yield Pressure	150 psi (10 bar)
Temperature Range	-20°F to 225° (-29°C to 107°C)
Porting Base	Cast Aluminum
Element Case	Steel
Weight	5 lbs (2.3 kg) FMS-3/0.4-P 6 lbs (2.7 kg) FMS-3/25-P
Element Change Clearance	2.5" (65 mm)

ELEMENT REPLACEMENT INSTRUCTION

FMS-3/0.4-P



ELEMENT INSTALLATION

- Shut down the system to ensure there is no pressure or flow in the filter housing.
- Remove element by turning bowl counterclockwise.
- Discard the old/used item.
- Select the item you want to install. Lubricate the O-ring on the element and inside the connection head.
- Install the element in the guide tube in the filter connection head.

ELEMENT TECHNICAL SPECIFICATIONS

Efficiency	Beta 4-4193 (ISO 16889:99)
DHC	100 grams (MTD) FMS-3/0.4-P
	155 grams (MTD) FMS-3/25-P
Maximum Flow	0.4 gpm
Max. Operating Pressure	100 psi (7 bar)
Min. Yield Pressure	150 psi (10 bar)
Dimensions	7.12 x 5.52 x 9.52" FMS-3/0.4-P
	10.80 x 5.52 x 9.52" FMS-3/25-P
Weight	5 lbs (2.3 kg)
Housings	FMS-0.4-SP

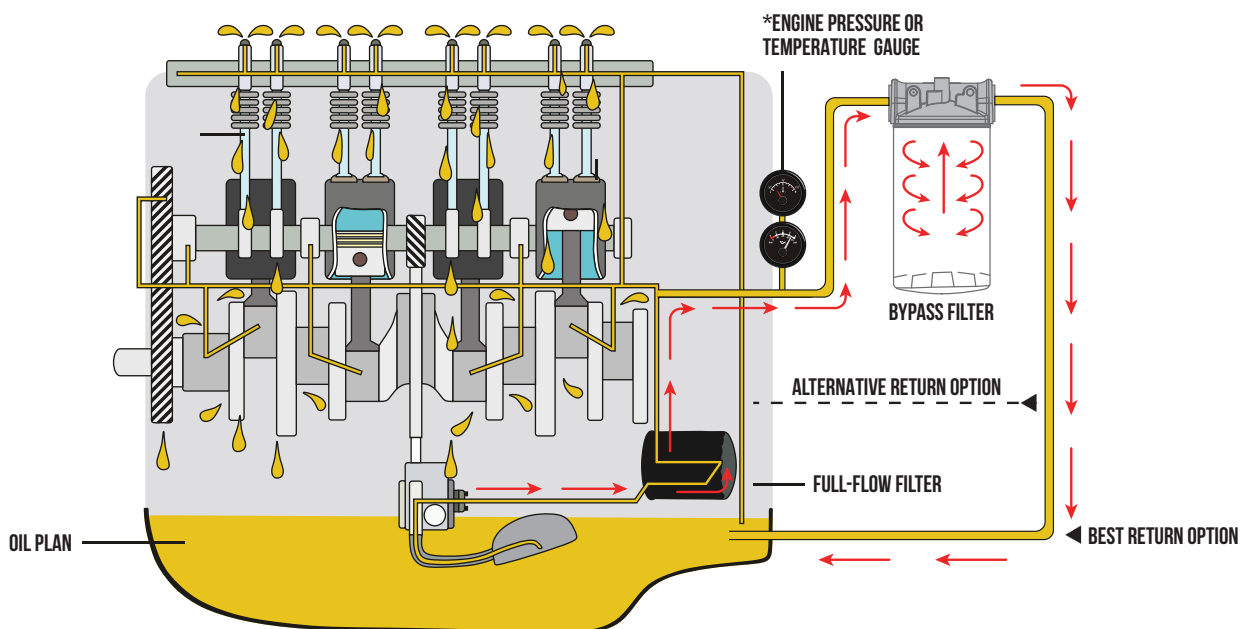



INSTRUCTIONS FOR MATERIALS

- Hoses that can tolerate: 150°C (at least), 200 psi (minimum) , crimped steel core (press-fitted with a special machine) to stainless steel or high-quality steel fittings (do not use adjustable metal bands, washers, or loops).
- If the hose must enter at a certain angle, DO NOT use additional couplings or force the hose, you must request the fittings that are crimped on the hose with the corresponding angle.
- The hoses must be fastened in some way to avoid damaging them, but above all to prevent any external object from pulling on them, causing damage to the system.
- The accessories, couplings or figures that are strictly necessary to use must be made of high quality stainless steel.
- Use high quality stainless steel lock nut, lock washers and bolts.
- Use in all threaded connections Loctite 243 (the one in blue).
- The base of the filter must be of high quality stainless steel and with an angle, it can be welded in its construction using high quality materials, but preferably it must be anchored (with bolts, pressure washers and pressure nuts) to the chassis of the unit to be installed, respecting the materials to be used according to additional instructions.
- Pressure gauges must tolerate 100C min; Minimes points can be installed and periodic saturation measurements can be made if there are no manometers that meet the temperature requirement.
- The reading range of the pressure gauges should be twice the engine pressure for safety matters.